

# Innovation



## MaxiMill 252

Double the number of cutting edges = double the economy



EN



## Application – customer benefits

### Industries

- Aerospace
- Power generation, turbine construction
- Mould and die production
- General mechanical engineering

### Materials

- Stainless steels
- High tensile stainless steels
- Titanium alloys
- Super alloys

### Typical components

- Engine components, in particular turbine blades
- Landing gear components
- Structural components

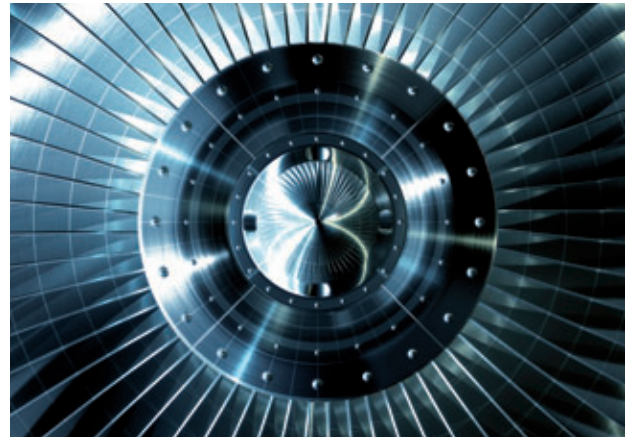

### Product advantages

Double the number of cutting edges combined with optimum depth of cut



Optimized chip geometry



Increased stability of both tools and inserts



Easy indexing positioning of the inserts



### YOUR benefits

Reduced costs per cutting edge

Secure swarf evacuation even with high feed rates per tooth

Maximum process security

User-friendly handling



# System MaxiMill 252

- 1 Slot milling
- 2 Turn-milling
- 3 Face milling
- 4 Reverse copy milling

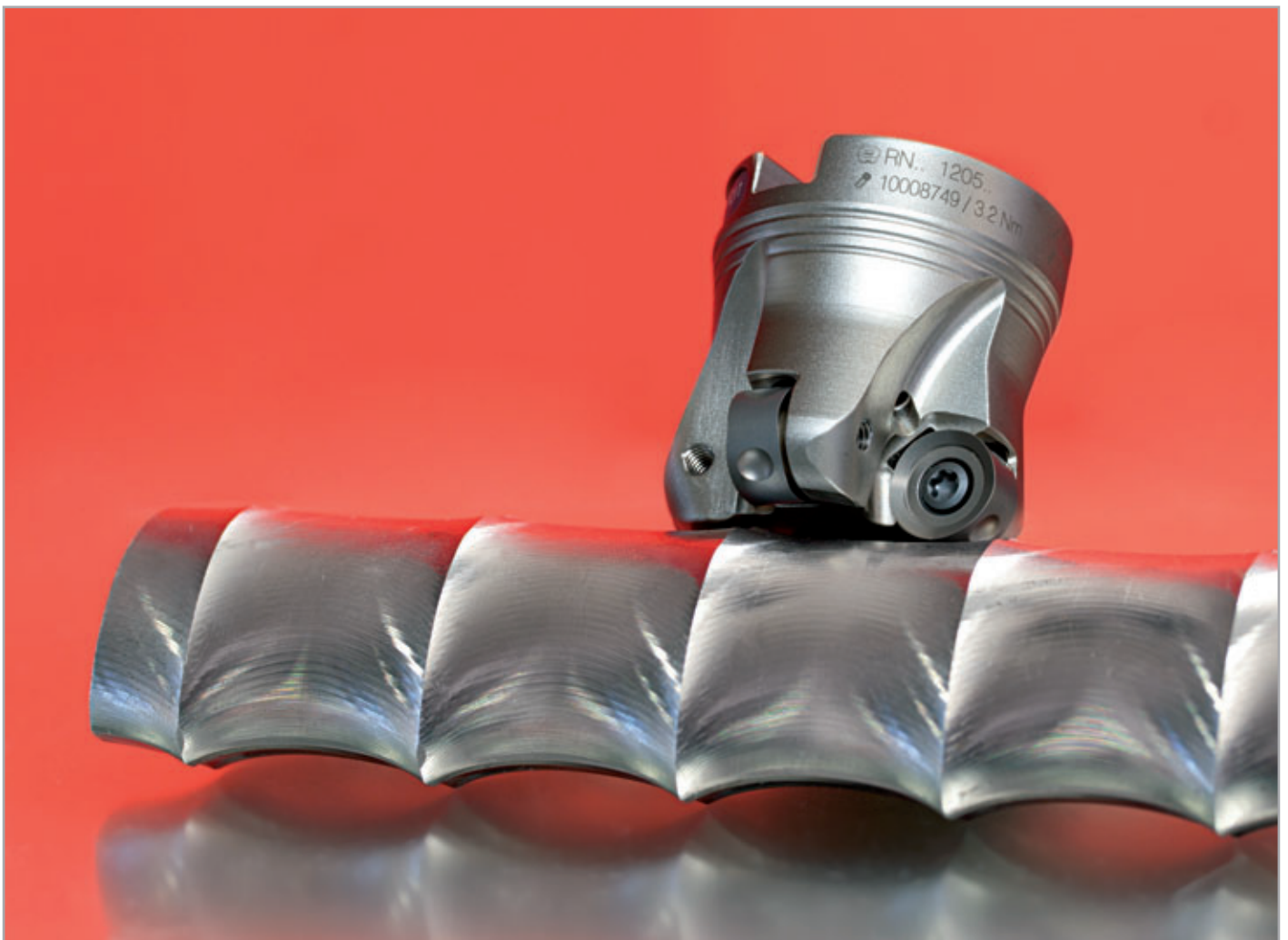
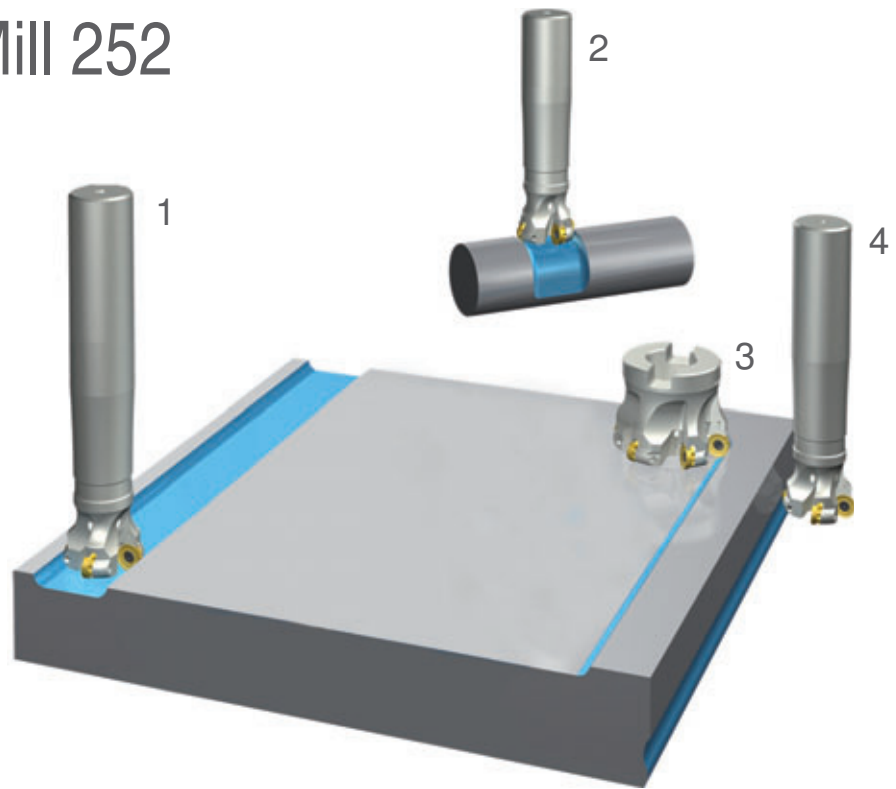



## Maximum performance

### System 252

- Extra stable - compact design
- Optimized chip pocket for long-chipping materials
- Insert seat with index
- Power screw with Ø 40 mm
- hard & tough** tool coating
- Coolant hole optimized for MQL (minimum quantity lubrication)

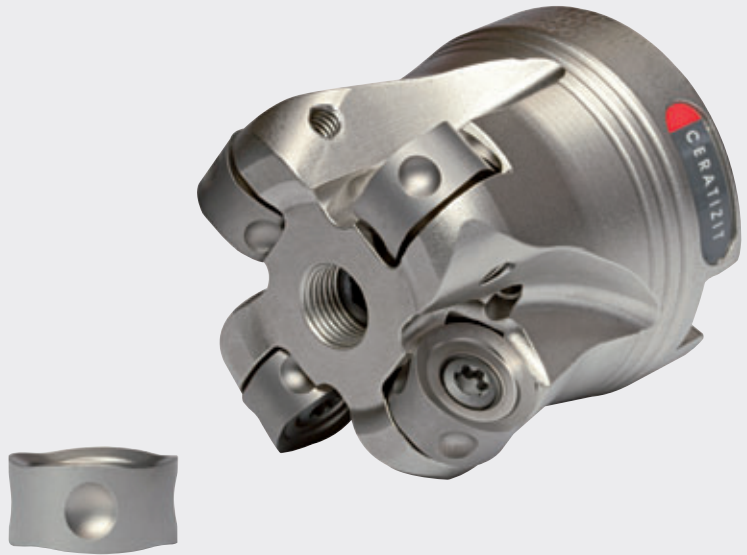

## The grades

- Extraordinary heat resistance
- High toughness
- Excellent resistance to notching
- CVD high-performance coating with maximum hardness and extremely smooth surface

### CTC5235

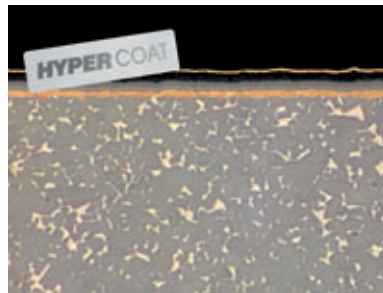

- High tensile stainless steels
- Steels in general
- Super alloys
- Spheroidal cast iron
- Dry machining, MQL (minimum quantity lubrication)

### CTC5240

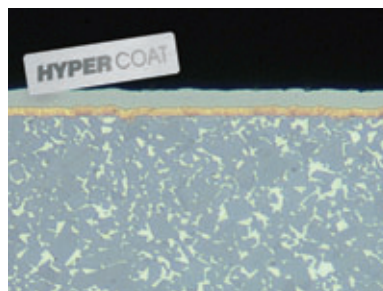

- Titanium alloys
- Super alloys
- Wet machining, MQL (minimum quantity lubrication)



# The geometries

## -M31

- Highly positive geometry for ideal swarf control and high feed rates
- Very positive geometry for a smooth cut
- 4 indexes to guarantee secure location
- 8 cutting edges



<b>Feed rate per tooth</b>	0.15 – 0.6 mm
<b>Materials</b>	heat resistant, stainless steels, super alloys, titanium alloys
<b>Grades</b>	CTC5235, CTC5240
<b>Indexes</b>	4 indexes, 8 cutting edges

## -M32

- Specialized geometry for ideal swarf control and high feed rates
- Smooth cut and stable geometry, particularly for martensitic steels
- 4 indexes to guarantee secure location
- 8 cutting edges



<b>Feed rate per tooth</b>	0.3 mm and greater
<b>Materials</b>	martensitic, heat resistant Cr-Ni steels
<b>Grades</b>	CTC5235
<b>Indexes</b>	4 indexes, 8 cutting edges



# RNHU



-M31



-M32

d [mm]	Type, description	L R	CTC5235		CTC5240		d <sub>1</sub> [mm]	s [mm]
10	RNHU 1004M4ER-M31	R	●	●			3,4	4,6
10	RNHU 1004M4ER-M32	R	●				3,4	4,6
12	RNHU 1205M4ER-M31	R	●	●			4,4	5,3
12	RNHU 1205M4ER-M32	R	●				4,4	5,3



Steel	○	●	●	●	●
Stainless	○	●	●	●	●
Cast iron	○	●	●	●	●
Non ferrous metals	○	●	●	●	●
Heat resistant	○	●	●	●	●
Hard materials	○	●	●	●	●

- Main application
- Extended application
- International CERATIZIT range, for present availability see price list

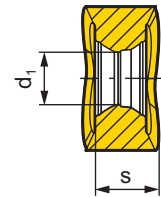
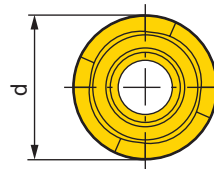

Ordering example: 10 pieces RNHU 1004M4ER-M31 CTC5235

# G252

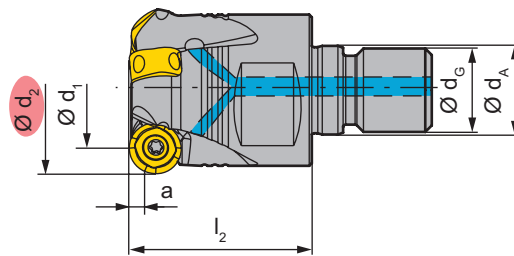

d <sub>2</sub> [mm]	Type, description	d <sub>1</sub> [mm]	l <sub>2</sub> [mm]	d <sub>A</sub> [mm]	d <sub>g</sub>	a [mm]	z	RNHU 1004..
32	G252.32.R.04-10	22	35	17	M16	2,5	4	RNHU 1004..



Ordering example: 1 piece G252.32.R.04-10

**Supply details:** cutter body and insert clamping screws

	d <sub>2</sub> [mm]			
RNHU 1004..	32		10009229/M3X7,5/10IP	
			10009377/TORX 10IP	
				DMSD 2,0Nm/SORT 10IP

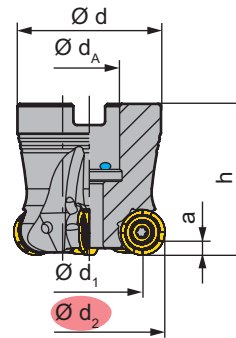





# A252



$d_2$ [mm]	Type, description	$d_1$ [mm]	$h$ [mm]	$a$ [mm]	$d$ [mm]	$d_A$ [mm]		
40	A252.40.R.05-10	30	40	2,5	38	16	5	RNHU 1004..
42	A252.42.R.05-10	32	40	2,5	38	16	5	RNHU 1004..
50	A252.50.R.06-10	40	40	2,5	43	22	6	RNHU 1004..
52	A252.52.R.07-10	42	40	2,5	43	22	7	RNHU 1004..
40	A252.40.R.04-12	28	40	3,0	38	16	4	RNHU 1205..
50	A252.50.R.05-12	38	40	3,0	43	22	5	RNHU 1205..
52	A252.52.R.05-12	40	40	3,0	43	22	5	RNHU 1205..
63	A252.63.R.06-12	51	40	3,0	48	22	6	RNHU 1205..
66	A252.66.R.07-12	54	40	3,0	48	22	7	RNHU 1205..
80	A252.80.R.08-12	68	50	3,0	58	27	8	RNHU 1205..



Ordering example: 1 piece A252.40.R.05-10

Supply details: cutter body and insert clamping screws

	$d_1$ [mm]					
RNHU 1004..	40-52	10009229/M3X7,5/10IP	10009377/TORX 10IP	DMSD 2,0Nm/SORT 10IP	-	-
RNHU 1205..	50-80	10008749/M3,5X8,6/15IP	10006919/TORX 15IP	DMSD 3,2Nm/SORT 15IP	-	-
A252.40..-12	40	10008749/M3,5X8,6/15IP	10006919/TORX 15IP	DMSD 3,2Nm/SORT 15IP	7818267/M8,0X30,0	S4/SW4

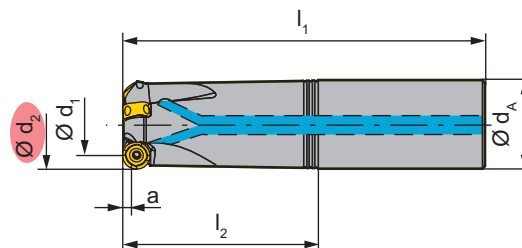



# C252



$d_2$ [mm]	Type, description	$d_1$ [mm]	$l_1$ [mm]	$l_2$ [mm]	$d_A$ [mm]	$a$ [mm]		
32	C252.32.R.04-10-A-70	22	131	70	32	2,5	4	RNHU 1004..

Ordering example: 1 piece C252.32.R.04-10-A-70

Supply details: cutter body and insert clamping screws

	$d_2$ [mm]			
RNHU 1004..	32	10009229/M3X7,5/10IP	10009377/TORX 10IP	DMSD 2,0Nm/SORT 10IP

## CERATIZIT worldwide

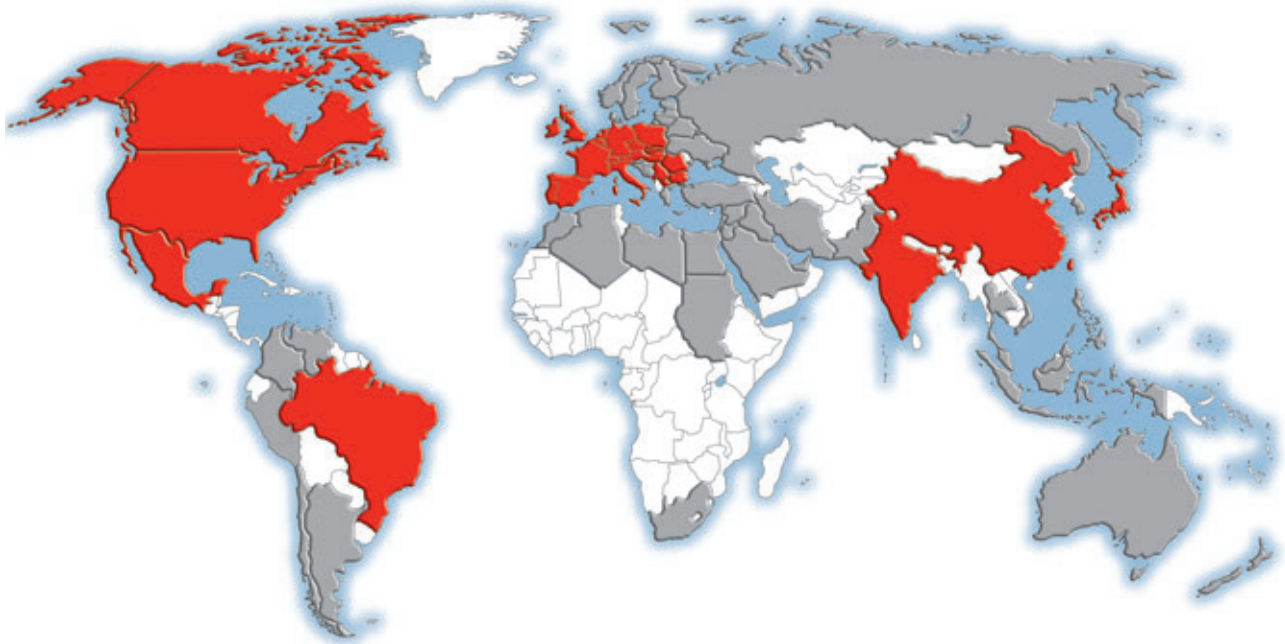

- CERATIZIT worldwide production sites and support centres
- CERATIZIT worldwide distribution partner network



[www.ceratizit.com](http://www.ceratizit.com)

**Parent company: CERATIZIT S.A.**

Route de Holzem 101  
L-8232 Mamer  
Tel.: +352 312 085-1  
Fax: +352 311 911  
E-mail: [info@ceratizit.com](mailto:info@ceratizit.com)

**Contact for further information:**

**CERATIZIT Austria Gesellschaft m.b.H.**  
6600 Reutte/Tyrol

Tel.: +43 (5672) 200-0  
Fax: +43 (5672) 200-502  
E-mail: [info.austria@ceratizit.com](mailto:info.austria@ceratizit.com)

